

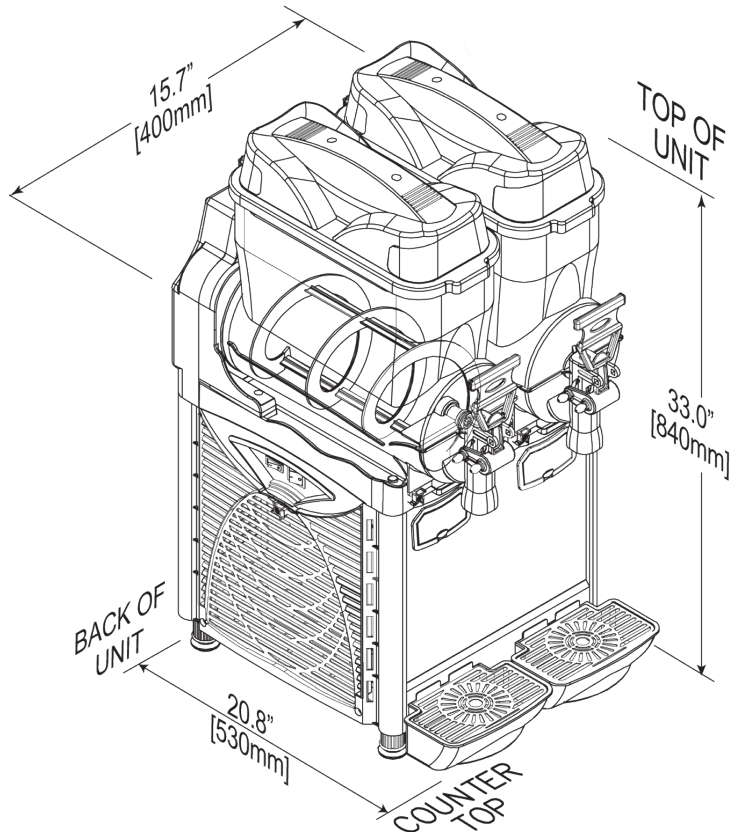

Frozen Beverage Dispensers
EVERYONE LOVES FROZEN™

OASIS



SPECIFICATIONS

DIMENSIONS

Countertop unit:
Width: 15.7 in (400 mm)
Depth: 20.8 in (530 mm)
Height: 33.0 in (840 mm)

CAPACITY (60Hz)

Bowl size: (2) 2.6 gal (10 lt.)

ELECTRICAL REQUIREMENTS

115/120 VAC, 60Hz

REFRIGERATION

2544 BTU/Hr, R-404A (60Hz)

SPACE REQUIREMENTS

Air cooled unit requires 10" of clearance

WEIGHT

Operating unit: 123 lb (56.0 kg)

OPTIONAL ACCESSORIES

Auto-Fill (Part #12-9600-2301)



MADE IN ITALY BY COFRIMELL

ROHS Compliant. FBD strives for continuous improvements and engineering innovations. Equipment design and/or specifications may change without notice. FBD - Frozen Beverage Dispensers . 8161 Interchange Parkway, Suite 115 • San Antonio, TX 78218 • 210.637.2800 • 1.866.323.2777 • Fax: 210.637.2844 • www.fbd frozen.com • ©2016 FBD Partnership, LP. FBD®, the FBD logo, and "Everyone Loves Frozen™" are trademarks of FBD Partnership, LP; all rights reserved.

FBD Partnership, LP | 866.323.2777 | sales@fbd frozen.com | fbd frozen.com



Frozen Beverage Dispensers
EVERYONE LOVES FROZEN™

OASIS

PRODUCT FEATURES



- Flex design allows for frozen or chilled product to be dispensed.
- Auto-Defrost mode with configuration defrost timer maintains continuous product consistency.
- Environmentally friendly by utilizing CFC free refrigerant.
- SS 304 one-piece evaporator enhances performance and increases reliability.
- No tools required for bowl disassembly.
- Valve design enables operator to lock and protect the equipment.
- Auto-Fill available.
- Small footprint: 15.75"W x 20.87"D x 33.07"H
- ADA lever optional.



MADE IN ITALY BY COFRIMELL