



773

773 (60 HZ) SPECIFICATIONS

DIMENSIONS

Countertop Unit:

Width: 20.3 in. (516 mm)

Depth: 32.5 in. (826 mm)

Height: 41.4 in. (1,052 mm) with Merchandiser Door

CAPACITY

Barrel Size: 176 oz

Continuous Draw (alternating barrels): 5,160 oz/hour

Recovery Time (75°F ambient): 4 Minutes

ELECTRICAL REQUIREMENTS

208-254 VAC (buck and boost transformer required for operation outside this range)

Single Phase, 3 Wire, 30 Amp

Uses NEMA #L-630R Receptacle

REFRIGERATION

19,000 BTU/Hr, R-404A

SPACE REQUIREMENTS

Sides or Back: 3 in. (76 mm) Minimum

Top: 36 in. (914 mm) Minimum

WEIGHT

Empty unit: 359 lbs (163 kg)

Operating Unit: 393 lbs (178 kg)

Base Cabinet: 74 lbs (34 kg)

SYRUP CONNECTION

Bag-In-Box (BIB)

MOTORS

Beater: (3) 1/6 HP (120 W)

Fan: 1/4 HP (135 W)

WATER REQUIREMENTS

Fresh Water, Minimum 3/8" Supply, 30 psi Flowing (207 kPa)

Water Flow Rate: 1.5 oz/sec from Solution Module

CO₂ SYSTEM

Supply Pressure: 70-72 psig

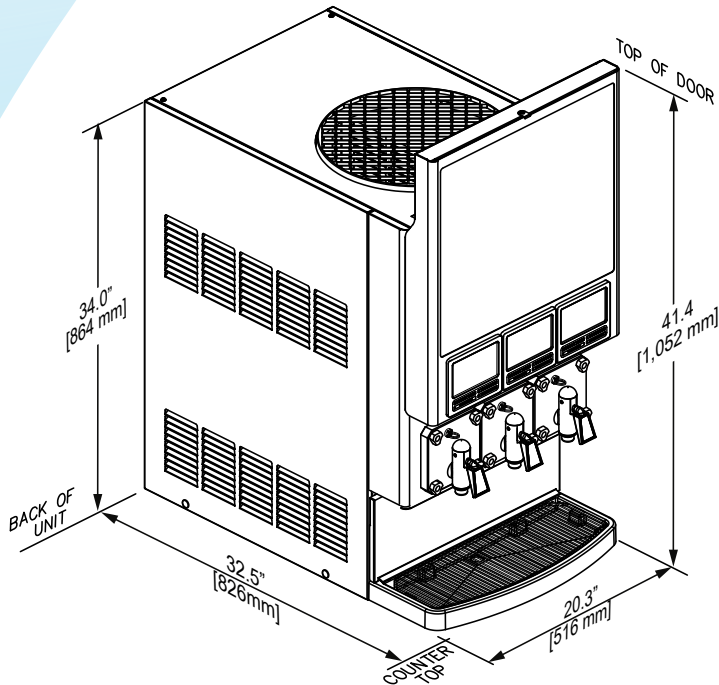

Intertek



Intertek



OPTIONAL ACCESSORIES

Base Cabinet with Casters

Leg Kit (set of four)

Painted Or Stainless Steel Sheet Metal

Water-Cooled Unit

Merchandiser Options

BIB Rack

Install Kit

773



Frozen Beverage Dispensers
EVERYONE LOVES FROZEN™



Frozen Beverage Dispensers

EVERYONE LOVES FROZEN™

773



Setting a new standard in frozen, the 77X series combines the superior quality found in all FBD equipment with a range of engineering breakthroughs to create the most innovative frozen beverage dispenser in the world. Featuring an improved capacity and refrigeration system, the 77X is able to dispense more high quality product than ever before while incorporating cost-reducing functions such as easier troubleshooting and improved serviceability. The productivity and efficiency of the 77X delivers a powerful message: High profitability. Low Operating Cost.

Everyone Loves Frozen. You'll love frozen more with 77X.

ADVANCEMENTS

- LED Light Guided Panel – optimized lighting for better, brighter merchandising.
- Simplified User Interface – more intuitive menu interface for an easier, improved user experience.
- BevTrak™ Remote Monitoring – remote monitoring with built-in diagnostics for faster troubleshooting to minimize machine downtime and lost sales.
- On-Screen QR code display for instant access to service information and procedures.
- Integrated Service Platform and removable solution modules for enhanced serviceability.
- Drop-In Control Board – consolidates three board platforms into a single board for easier diagnostic troubleshooting and decreased service related downtime.

PRODUCT FEATURES

- Energy Saving Software – provides 35.6% annual energy savings with no effect on drink quality through smart compressor cycle and motor management.
- Inline Carbonation™ – allows for more consistent expansion, quality and yield.
- OptiFreeze™ Technology – maintains product consistency to deliver the most consistent froze beverage, drink after drink.
- RapidFreeze™ – cold chamber system improves refreeze time while reducing the compressor workload and increasing dispenser durability.
- Scroll™ Compressor – provides more reliable operation and fewer moving parts than reciprocating compressors.
- Customizable individual barrels allow for hundreds of different drink profile combinations which include sugar-free options.

773

FBD Partnership, LP | 866.323.2777 | sales@fdbfrozen.com | fdbfrozen.com

ROHS Compliant. FBD strives for continuous improvements and engineering innovations. Equipment design and/or specifications may change without notice. FBD Partnership, LP • 8161 Interchange Parkway, Suite 115 • San Antonio, TX 78218 • 210.637.2800 • 1.866.323.2777 • Fax: 210.637.2844 • www.fdbfrozen.com • ©2017, 2018 FBD Partnership, LP. FBD®, the FBD logo, and "Everyone Loves Frozen™" are trademarks of FBD Partnership, LP, all rights reserved.