

561

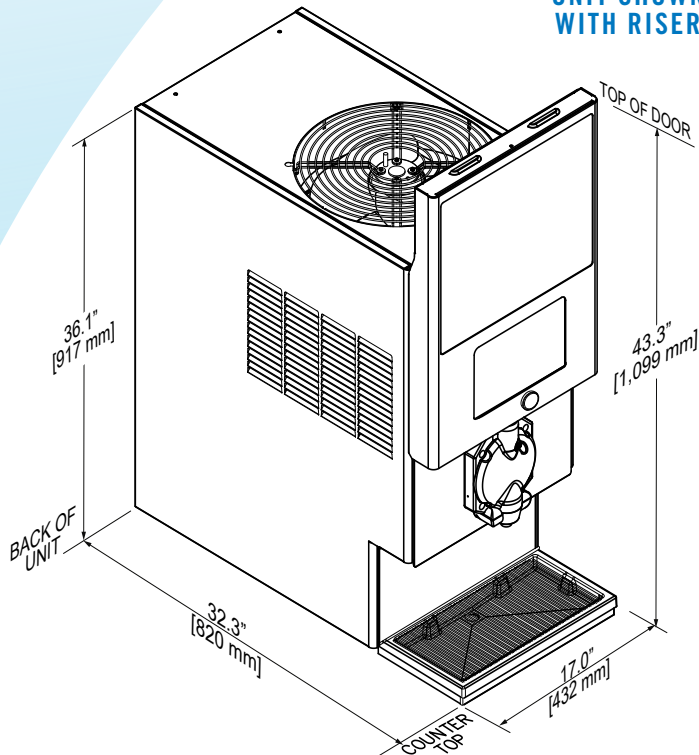

UNIT SHOWN
WITH RISER



1965

561 (60HZ) SPECIFICATIONS

DIMENSIONS

Width: 17 in. (432 mm)
Depth: 32.3 in. (820 mm)
Height: 36.1 in. (917 mm) with 2" Riser
43.3 in. (1,099 mm) with Merchandiser Door and 2" Riser

CAPACITY

Barrel Size: 184 oz
Continuous Draw: 3,600 oz/hour (base flavor, FCB)
Maximum Capacity (75°F ambient): 60 oz/min
Recovery Time (75°F ambient): 4 Minutes
Defrost Schedule: Auto-Defrost Every Three Hours w/ Programmable Blackout Times

ELECTRICAL REQUIREMENTS

208 - 254V (60Hz) (buck and boost transformer required for operation outside this range)
Single Phase, 3 Wire, 20 Amp
Uses NEMA #L-620R Receptacle

REFRIGERATION

15,000 BTU/Hr, R-404A

SPACE REQUIREMENTS

Sides or Back: 2 in. (51 mm) Minimum
Top: 12 in. (305 mm) Minimum

WEIGHT

Empty Unit: 273 lbs (124 kg)
Operating Unit: 308 lbs (139 kg)
Base Cabinet: 67 lbs (30 kg)

SYRUP

(1) Base Syrup
(4) Flavor Injection Syrups
Bag-In-Box (BIB) Connections

MOTORS

Beater: (1) 1/6 HP (120 W)
Fan: 1/4 HP (135 W)

WATER REQUIREMENTS

Fresh Water, Minimum 3/8" Supply, 30 psi Flowing (207 kPa)
Water Flow Rate: 1.5 oz/sec from Solution Module

CO₂ SYSTEM

Supply Pressure: 70-72 PSIG

OPTIONAL ACCESSORIES

Painted or Stainless Steel Sheet Metal
Base Cabinet with Casters
Leg Kit (set of four)
Install Kit (12-2474-0073)
Water-Cooled Unit (12-2817-0012)



Frozen Beverage Dispensers
EVERYONE LOVES FROZEN™



Frozen Beverage Dispensers
EVERYONE LOVES FROZEN™

561

PRODUCT FEATURES



- Inline Carbonation™ – creates a more consistent over-run, quality, and yield.
- OptiFreeze™ Technology – maintains product consistency, delivering the most consistent frozen beverage, drink after drink.
- RapidFreeze™ – cold chamber system improves recovery and draw-time, while reducing the compressor workload and increasing dispenser durability.
- Electronic simplicity offers easy-to-use keypad interface.
- Optimal use of counter space with minimum ventilation of two inches side or back.
- Scroll™ Compressor – is more reliable during operation and has fewer moving parts than reciprocating compressors.
- Customizable individual barrels allows for hundreds of different drink profile combinations, including sugar-free options.
- ADA Compliant – four button design with graphical universal handicap image.
- 10.1" Color Touchscreen
- 15 Flavor Combinations
- Tactile Push Button Dispense
- Sold-Out Dispense Lockout
- Flavor Injection Mixing

TOUCH SCREEN AND ANCILLARY COMPONENTS

- Touch Screen: 10.1" Capacitive Touch LCD
- SD Card for Updating Content
- Push Button, LED Backlit, Centered Below Touch Screen

FBD Partnership, LP | 866.323.2777 | sales@fbdfrozen.com | fbdfrozen.com

ROHS Compliant. FBD strives for continuous improvements and engineering innovations. Equipment design and/or specifications may change without notice. FBD Partnership, LP, 8161 Interchange Parkway, Suite 115 • San Antonio, TX 78218 • 210.637.2800 • 1.866.323.2777 • Fax: 210.637.2844 • www.fbdfrozen.com • © 2017, 2018 FBD Partnership, LP. FBD®, the FBD logo, and "Everyone Loves Frozen"™ are trademarks of FBD Partnership, LP, all rights reserved.

561