





773

PRODUCT SPECIFICATIONS



Capacity

Electric Frequency	60 Hz			50 Hz		
Dispenser Type	Air-Cooled	Remote	Water-Cooled	Air-Cooled	Remote	Water-Cooled
Barrel Volume	176 oz	176 oz	176 oz	5,205 mL	N/A	N/A
Continuous Draw - Single Barrel [§]	-	-	-	92,269 mL/hr	N/A	N/A
Continuous Draw - Alternating Barrels [§]	5,160 oz/hr	5,760 oz/hr	5,580 oz/hr	127,758 mL/hr	N/A	N/A
Recovery Time [§]	4 mins	3.5 mins	3.5 mins	4 mins	N/A	N/A
Refrigeration	19,000 BTU/hr (20,046 kJ/hr); R-404A/R-448A [†]					
Agency	NSF 18  Intertek UL/CSA 60335-1  Intertek			Complies with IEC/EN 60335-1; IEC/EN 60335-2-75; IEC/EN 60335-2-89; IEC/EN 61000-3-2; IEC/EN 61000-3-3; CISPR 14-1; CISPR 14-2.		
	Complies with UL 60335-1; UL 60335-2-89; IEC 60335-2-75.					

[§] Testing completed at 75°F (24°C).

[†] R-404A and R-448A refrigeration systems are functionally equivalent.

Electrical Requirements[‡]

Electric Frequency	60 Hz	50 Hz
Voltage	215 - 245 VAC ^Δ , Single Phase	215 - 245 VAC ^Δ , Single Phase
Current/Power	30 Amps	3,120 W
Receptacle	NEMA #L6-30R, 3 Wire	Varies depending on market.
Beater Motor	(3) 1/6 HP, 0.85 A	(3) 1/6 HP, 0.81 A
Fan Motor	(1) 1/4 HP, 0.83 A	(1) 1/6 HP, 0.60 A

[‡] General requirements only. Always check dispenser nameplate label for specific rating information.

^Δ Buck-boost transformer required for operation outside this range.

ROHS Compliant. FBD strives for continuous improvements and engineering innovations. Equipment design and/or specifications may change without notice.
 ©2020, FBD Partnership, L.P. FBD®, the FBD logo, and "Everyone Loves Frozen™" are trademarks of FBD Partnership, L.P., all rights reserved.



Frozen Beverage Dispensers
EVERYONE LOVES FROZEN™

773

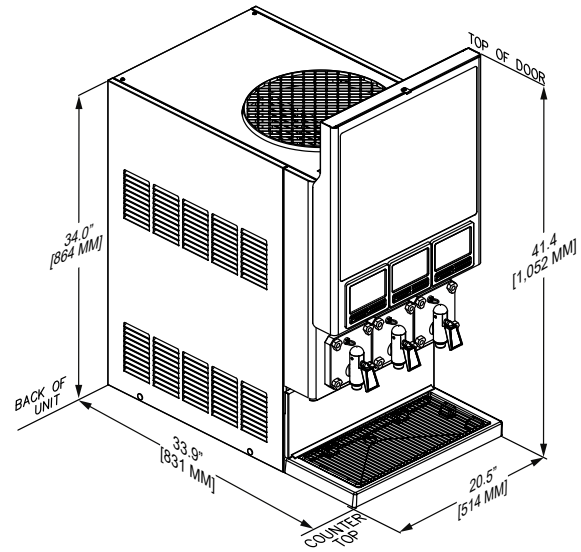
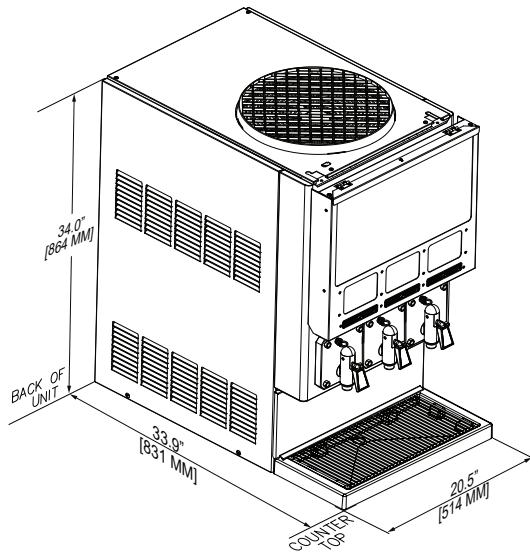

Weights & Dimensions

Measuring System	Imperial			Metric		
Door Model	Short Door	Tall Door		Short Door	Tall Door	
Height	34.0 in	41.4 in		864 mm	1,052 mm	
Width	20.3 in			516 mm		
Depth	32.5 in			826 mm		
Back/Side Clearance (Min.)	3 in			76 mm		
Top Clearance (Min.)	12 - 36 in*			304 - 914 mm*		
Duratrans	10 in X 20 in	17 ³ / ₄ in X 20 in		254 mm x 508 mm	451 mm x 508 mm	
Flavor Card	4 ⁷ / ₈ in x 3 ¹ / ₂ in			124 mm x 89 mm		
Dispenser Type	Air-Cooled	Remote	Water-Cooled	Air-Cooled	Remote	Water-Cooled
Empty Weight	359 lbs	343 lbs	356 lbs	163 kg	156 kg	162 kg
Operating Weight	393 lbs	377 lbs	390 lbs	178 kg	171 kg	177 kg

* 12 in (304 mm) with side or back open-air conditions, 36 in (914 mm) in equipment alcove.

Water, CO₂ and Syrup Requirements

Measuring System	Imperial	Metric
Water System Input	3/8" Supply Line, 30 PSIG Flowing (minimum)	3/8" Supply Line, 207 kPag Flowing (minimum)
CO ₂ System Input	70 - 72 PSIG (maximum)	483 - 496 kPag (maximum)
Condenser Water Inlet Flow Rate ^o	1 - 3 gal / min	3.8 - 11.4 L/min
Condenser Water Inlet Temperature ^o	40 - 90° F	4.4 - 32° C
Syrup	Input: 70 - 72 PSIG (483 - 496 kPag)	
	Bag-In-Box (BIB) Connections, (3) Base Syrups	

^o For water-cooled dispensers.