





772 FROZEN COCKTAIL MULTI-FLAVOR

PRODUCT SPECIFICATIONS



Capacity

Electric Frequency	60 Hz		
Dispenser Type	Air-Cooled	Remote	Water-Cooled
Barrel Volume	184 oz	-	-
Continuous Draw - Single Barrel [§]	1260 oz/hr	-	-
Continuous Draw - Alternating Barrels [§]	-	-	-
Recovery Time [§]	4 mins	-	-
Refrigeration	9,975 BTU/hr (10,524 kJ/hr), R-448A		
Agency	NSF 18 	UL/CSA 60335-1 	Complies with UL 60335-1; UL 60335-2-89; IEC 60335-2-75.

[§] Testing completed at 75°F (24°C).

Water, CO₂ and Syrup Requirements

Measuring System	Imperial	Metric
Water System Input	N/A	N/A
CO ₂ System Input	70 - 72 PSIG (maximum)	483 - 496 kPag (maximum)
Condenser Water Inlet Flow Rate [°]	1 - 3 gal / min	3.8 - 11.4 L / min
Condenser Water Inlet Temperature [°]	40 - 90° F	4.4 - 32° C
Syrup	Input: 70 - 72 PSIG (483 - 496 kPag)	
	Bag-In-Box (BIB) Connections, (2) Base Syrup and (8) Flavor Injection Syrups	
Non refrigerated, single strength, no seed, no pulp, < 14% ABV, product only. Non alcoholic drinks brix 15 - 18.		

[°] For water-cooled dispensers.

ROHS Compliant. FBD strives for continuous improvements and engineering innovations. Equipment design and/or specifications may change without notice.
©2023, FBD Partnership, L.P. FBD®, the FBD logo, and "Everyone Loves Frozen®" are trademarks of FBD Partnership, L.P., all rights reserved.

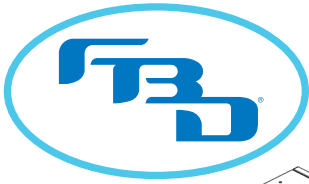

Frozen Beverage Dispensers
EVERYONE LOVES FROZEN®

772 FC + MFLV

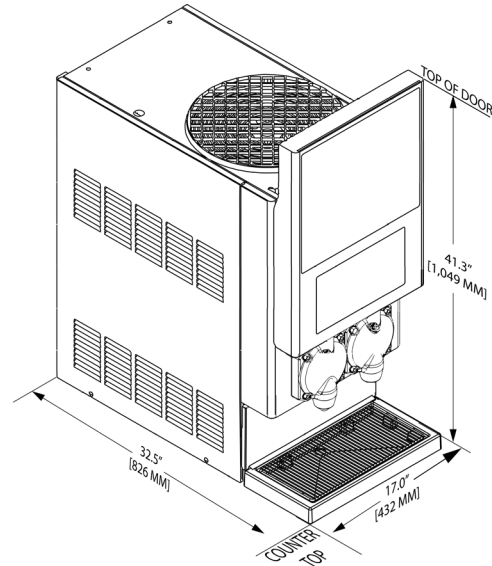
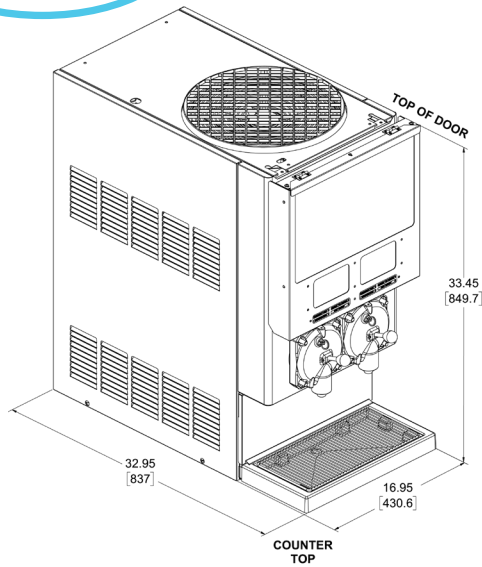

Weights & Dimensions

Measuring System	Imperial			Metric		
Door Model	Short Door	Tall Door		Short Door	Tall Door	
Height	34.0 in	41.3 in		864 mm	1,049 mm	
Width	17.0 in			432 mm		
Depth	32.5 in			826 mm		
Back/Side Clearance (Min.)	3 in			76 mm		
Top Clearance (Min.)	12 - 36 in*			304 - 914 mm*		
Duratrans	6 1/2 in x 15 3/4 in	14 1/8 in x 15 3/4 in		165 mm x 400 mm	359 mm x 400 mm	
Screen Size	13.3 in Touch Screen			338 mm Touch Screen		
Dispenser Type	Air-Cooled	Remote	Water-Cooled	Air-Cooled	Remote	Water-Cooled
Empty Weight	310 lbs	-	-	141 kg	-	-
Operating Weight	333 lbs	-	-	151 kg	-	-

* 12 in (304 mm) with side or back open-air conditions, 36 in (914 mm) in equipment alcove.

Electrical Requirements‡

Electric Frequency	60 Hz
Voltage	215 - 245 VAC ^Δ , Single Phase
Current/Power	30 Amps
Receptacle	NEMA #L6-30R, 3 Wire
Beater Motor	(2) 1/6 HP, 0.85 A
Fan Motor	(1) 1/4 HP, 0.83 A

‡ General requirements only. Always check dispenser nameplate label for specific rating information. ^Δ Buck-boost transformer or AVR required for operation outside this range.